

REV	ECN No.	DESCRIPTION	DESIGN	DATE
A0		Release	蒋建银	2017.09.22

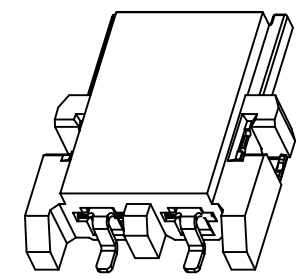
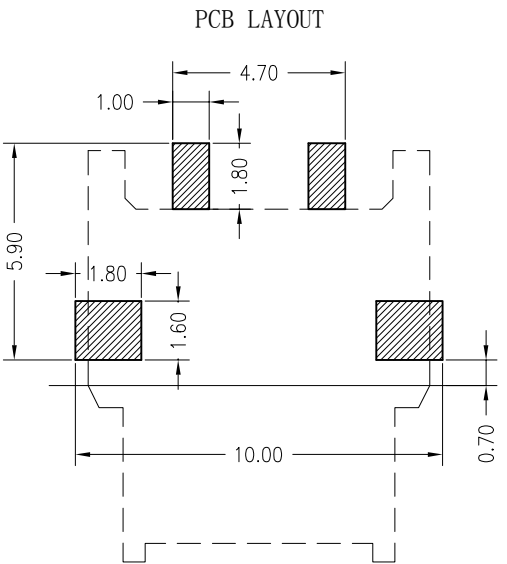
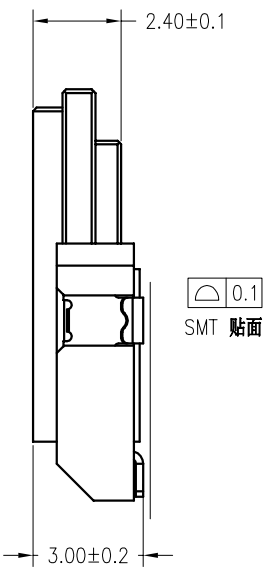
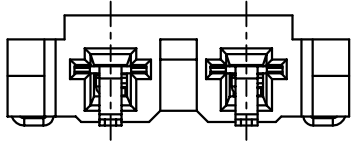
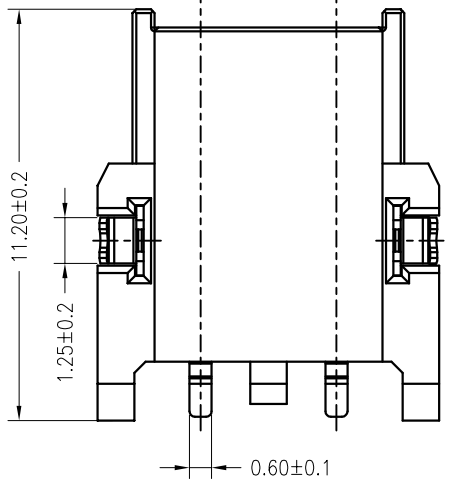
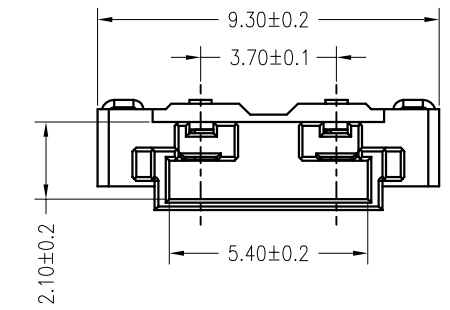

**主要技术参数 Main Specifications**

- 线 数 (Poles): 02
- 接触电阻 (Contact resistance):  $\leq 30m\Omega$
- 绝缘电阻 (Insulation resistance):  $\geq 1000M\Omega$
- 额定电压 (Rated voltage): 500V AC DC
- 额定电流 (Rated current): 2A AC DC
- 耐 电压 (Withstand Voltage): 1500V AC/minute
- 温度范围 (Temperature Range):  $-40^{\circ}C \sim +85^{\circ}C$

ORDER INFORMATION:

B3701P-02-F4MB1-R	
PART No.:	PACKAGING:
No.OF CIRCUITS:	B=BEEL
PLASTIC MATERIAL:	1=PhosphorBronze
F4M=LCP(BEIGE)	PLATING:
	B=MATTE Sn

ITEM	COMPONENT	Q'TY	MATERIAL	FINISH
C	COLDER TAB	2 PCS	PhosphorBronze	MATTE Sn
B	CONTACT	2 PCS	PhosphorBronze	MATTE Sn
A	HOUSING	1 PCS	LCP	UL 94V-0, COLOR:BEIGE

**东莞市高迪电子有限公司**  
DONG GUAN GAO DI ELECTRONICS CO., LTD

TITLE: -  
3.7mmPITCH 90° WAFER SMT TYPE

X.±0.5	X.±5'	USE:	CUSTOMER
.X±0.3	.X±2'	APPD:	
.XX±0.25	.XX±1'	CHKD:	谭龙清
--	--	DR:	田峰
⊕	◁	UNITS:	DR: 蒋建银
		mm	

PART NO.:	B3701P-02-F4MB1-R
DWG NO.:	GCCP-0743
SCALE	SHEET
1 : 1	1 / 1

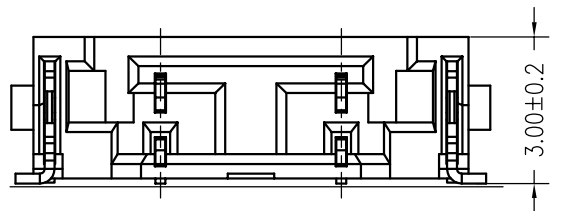
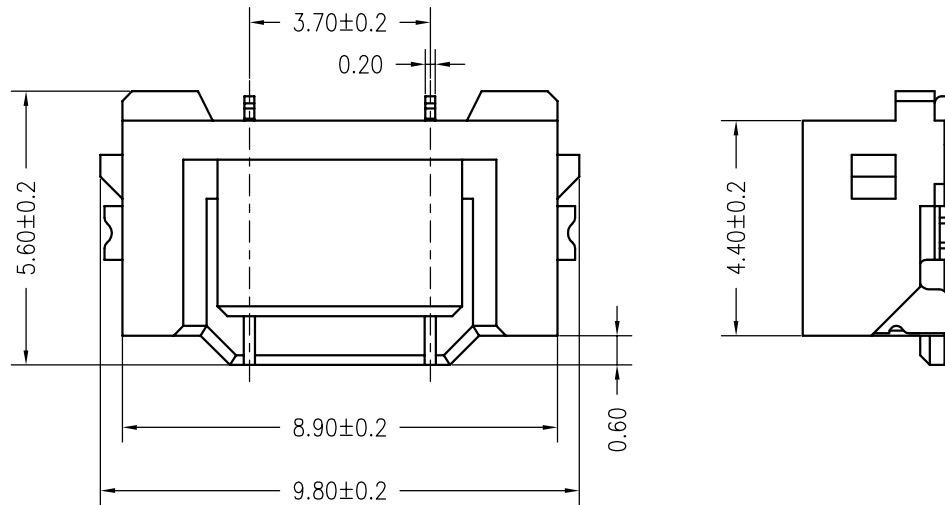

PCB LAYOUT

0.1

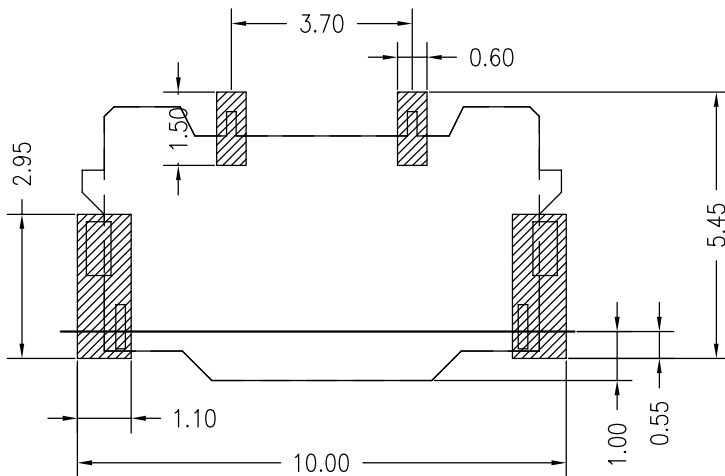

REV	ECN No.	DESCRIPTION	DESIGN	DATE
A0		Release	吴丹平	2017.09.22
A1		修改定位片	曾令青	2018.07.09

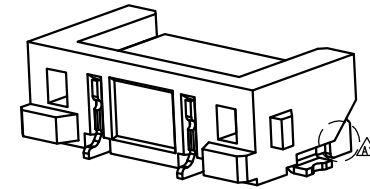

### 主要技术参数 Main Specifications

- 线数 (Poles): 02
- 接触电阻 (Contact resistance):  $\leq 30m\Omega$
- 绝缘电阻 (Insulation resistance):  $\geq 1000M\Omega$
- 额定电压 (Rated voltage): 500V AC DC
- 额定电流 (Rated current): 2A AC DC
- 耐电压 (Withstand Voltage): 1500V AC/minute
- 温度范围 (Temperature Range):  $-40^{\circ}C \sim +85^{\circ}C$

ORDER INFORMATION:

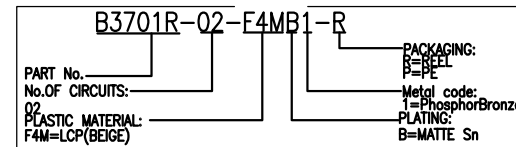

C	SOLDER TAB	2 PCS	PhosphorBronze	MATTE Sn
B	CONTACT	2 PCS	PhosphorBronze	MATTE Sn
A	HOUSING	1 PCS	LCP	UL 94V-0, COLOR:BEIGE
ITEM	COMPONENT	Q'TY	MATERIAL	FINISH

**东莞市高迪电子有限公司**  
DONG GUAN GAO DI ELECTRONICS CO., LTD

TITLE: B3701R-02  
3.7mmPITCH 90°WAFER SMT TYPE

X.±0.5	X.±5'	USE: CUSTOMER	PART NO.:	
.X±0.3	.X±2'		B3701R-02-F4MB1-R	
.XX±0.25	.XX±1'	APPD: 谭龙清	DWG NO.:	
--	--	CHKD: 田峰	GCKH-0744	
⊕	◁	DR: 蒋建银	SCALE 1 : 1	SHEET 1 / 1